

Lab 3: Diode circuits; power supplies and voltage regulation

Objectives:

- look at the current-vs.-voltage characteristics of diodes (Si and Ge)
- use diodes to perform half-wave and full-wave rectification of an AC signal
- see how diodes can be used to perform some operations such as clamping or limiting signals
- look at the properties of some simple voltage references
- design a simple DC power supply

3-1. Diode characteristics

Use the circuit shown below with an ammeter and a voltmeter in appropriate places to measure the DC voltage vs. current characteristics of a 1N914 (silicon) diode. Start by adjusting the power supply voltage to produce a current of about $10\ \mu\text{A}$ and then work up to about $10\ \text{mA}$, increasing the current by a factor of about 3 at each step. Turn the diode around and make a couple of measurements with the diode reversed. (Don't exceed about 10 volts with the diode reversed.)

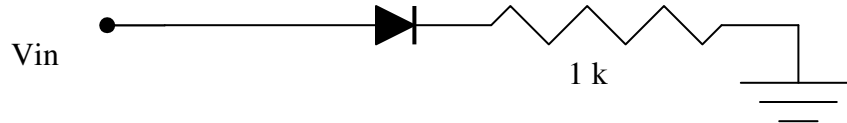

Plot I (y-axis) vs. V (x-axis) for the diode. What (roughly) is the "turn-on" forward voltage for this silicon diode?

What would happen if you didn't put the resistor in this circuit?

Have me show you how to use a curve tracer to obtain the I vs. V characteristics of the diode quickly and easily. Repeat for a Ge diode (1N100). What differences do you see between the 1N914 (Si) and the 1N100 (Ge)?

Try measuring the resistance of the Si (1N914) diode (forward and reversed). What are the results (and do they make sense)?

Finally, try the BK meter diode test function on the two diodes (forward and reversed). What do "good" diodes look like with this function?

3-2 Half-wave rectifier

Build the half-wave rectifier circuit below. Sketch the input and output wave forms, using the same horizontal and vertical scales for each. What is the peak V_{in} ? What is the peak V_{out} ? Explain what causes the difference between these values.

Does the polarity of the output make sense? What would you do if you wanted the opposite polarity?

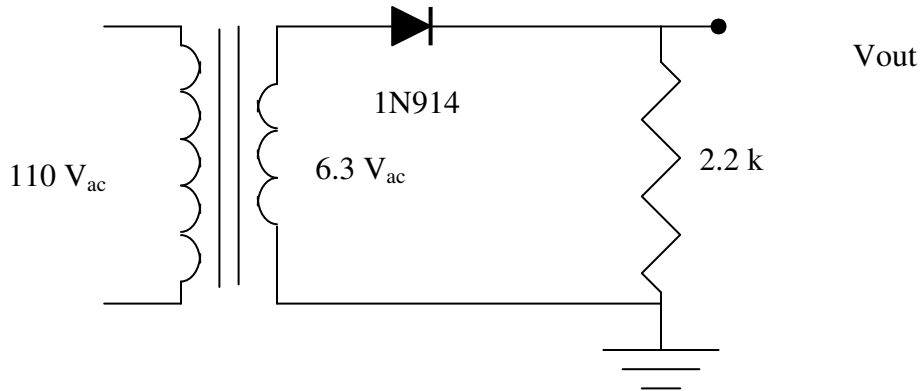

3-3 Full-wave bridge rectifier

Build the circuit below. Be careful to observe the diode polarities shown. Look at the output waveform with the scope, but ***don't*** attempt to look at the input at the same time. (Doing that would mean connecting the scope ground to one side of the secondary as well as to the indicated grounds. What disaster would that cause?)

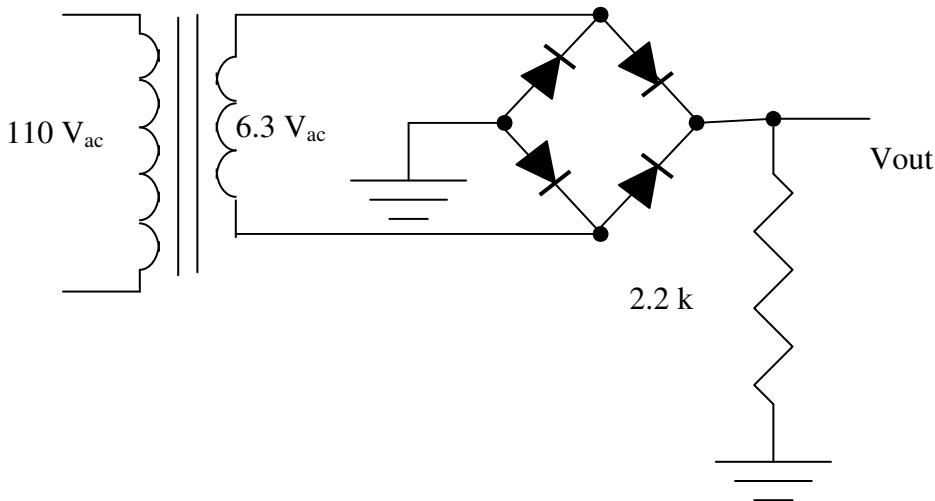

Sketch V_{out} carefully. What is the peak V_{out} ? Why is it less than in the last circuit? Note the flat region of near 0 V output. Measure its duration. Explain what causes the features of the output signal, including the value of the peak V_{out} and the flat region near 0 V.

What would happen if you were to reverse any of the four diodes? (Don't try it!)

3-4 Ripple voltage

Measure the ripple voltage ΔV for the full-wave bridge rectifier output. Now connect a $15 \mu\text{F}$ electrolytic capacitor in parallel with the load as a filter capacitor (caution: observe polarity). Sketch the output voltage. Make a calculation to predict what the ripple voltage should be, then measure it and compare. Write a sentence or two explaining how the capacitor reduces the ripple amplitude. Predict what will happen if you use a $68 \mu\text{F}$ capacitor instead; try it and comment on the results.

Leave the full-wave bridge rectifier set up to use again later.

3-5 Diode limiter

Build the circuit below and drive it with a sine wave of about 1 kHz from the function generator. Increase the amplitude of the sine wave from 0.1 V to several volts. Make a sketch of the input and output voltages for the highest voltage you use. Write a sentence or two explaining what the circuit does, including an explanation of the role of the diodes.

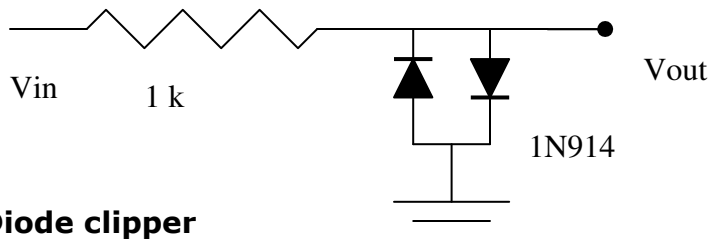

3-6 Diode clipper

Build the circuit below and drive it with a sine wave of about 1 kHz from the function generator. Increase the amplitude of the sine wave from less than a volt to at least 5 volts. Make a sketch of the input and output voltages for the highest voltage you use. Write a sentence or two explaining what the circuit does, including an explanation of the role of the diode. Why is the clamped voltage not quite flat?

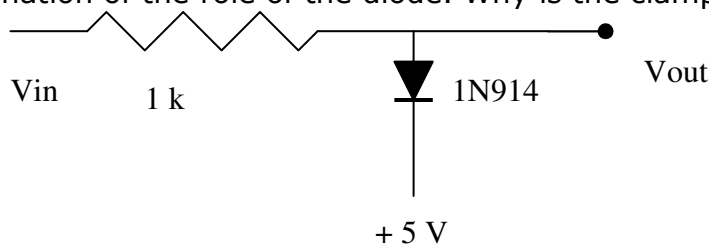

3-7 Voltage references

Using a Zener diode in its reverse breakdown or avalanche region can produce a fairly good voltage reference—one that does not vary much with current. To see how good a typical Zener is, hook it up as shown below (use an external power supply or the variable +V supply on your breadboard for V_{in}). The nominal breakdown voltage for the 1N5226 is 3.3 V. Before taking data, do a quick calculation to see if a $\frac{1}{4}$ -W resistor will be safe in this circuit (V_{in} can range from 0 up to 15 V). Measure V_{out} and the current for several different currents in the range 20 μ A to 20 mA.

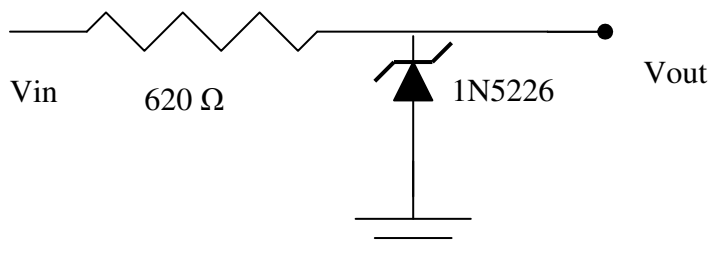

Now replace the Zener with an LM385-1.2 voltage reference and repeat (before doing so, think about whether the $\frac{1}{4}$ -W resistor will still be happy). Aside from the different value of the reference voltage, what difference(s) do you see between the Zener and the LM-385?

Now use the LM385 to regulate the output voltage of your full-wave bridge rectifier to 1.2 V. Sketch the output. Is there any measurable ripple?

3-8 Design problem: DC power supply

Modify your full-wave bridge rectifier so that it will provide a peak current of 5 mA with ripple of less than 1 V. (Hint: first choose the load resistor to meet the current specification, and then choose the filter capacitor to meet the ripple specification.)

Sketch a diagram of your design, build it, and record enough information to show that you have met the specifications.